

# Quality Steel Corporation AG/UG Propane Tanks

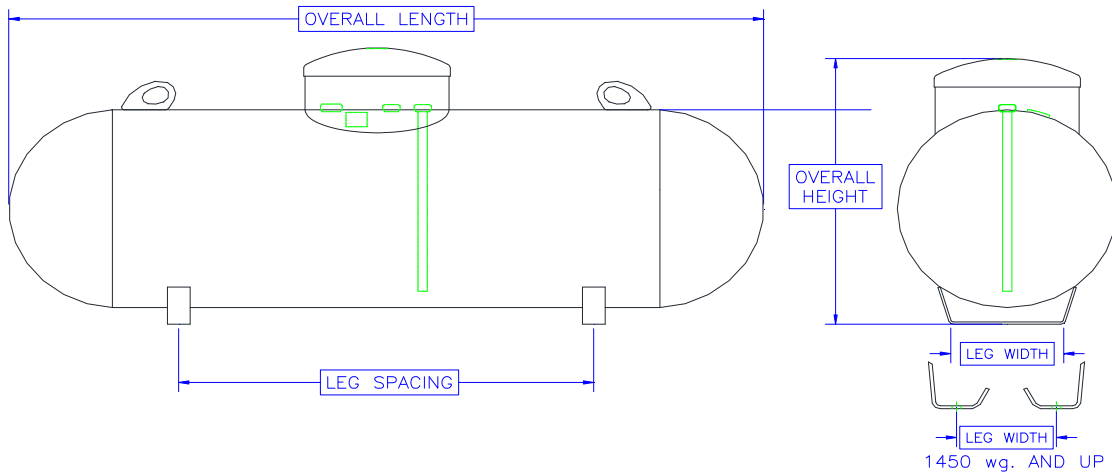

## APPROXIMATE ABOVEGROUND/UNDEGROUND (AG/UG) VESSEL DIMENSIONS AND SPECIFICATIONS

WATER CAPACITY	DIAMETER (OD)	HEAD TYPE	OVERALL LENGTH	OVERALL HEIGHT	LEG* WIDTH	LEG** SPACING	WEIGHT (lbs.)	**QUANTITY	
								FULL LOAD	PER STACK
*120 wg.	24"	Ellip.	5'-8"	3'	1'-1 1/2"	2'-10 1/2" or 3'-11"	260	108   96	16   12
*250 wg.	30"	Hemi.	7'-10"	3'-8"	1'-5"	4'-11"	480	54	9
*320 wg.	30"	Hemi.	9'-7"	3'-8"	1'-5"	5'	620	45	9
500 wg.	37 1/2"	Hemi.	10'	4'-2"	1'-8"	5'	950	37   30	8   6
1000 wg.	41"	Hemi.	16'	4'-5"	1'-8"	10'-1"	1,800	17   15	6   5
1450 wg.	46 1/2"	Ellip.	17'-4"	4'-11"	1'-9"	11'-7"	2,650	12	4
1990 wg.	46 1/2"	Ellip.	23'-11"	4'-11"	1'-9"	16'	3,520	8	4

Dimensions and specifications shown are approximate. Individual vessels may vary.

\* Leg spacing +/- 2". Leg widths and spacing may vary based on mfg. location. Check with your salesperson for details. 120, 250, 320 wg. standard tanks - no holes in legs (one center hole on request). 500 and 1000 wg. standard tanks - 2 holes 16" on center. 1450 wg. and up as shown above.

\*\* Full load and stack quantities vary by shipping location. Check with your salesperson for details.

### General Specifications

- Conforms to the latest edition of ASME Rules for Construction of Pressure Vessels, Section VIII, Division 1. Complies with NFPA 58.
- Rated at 250 psig from -20° F to 125° F. All vessels registered with National Board.
- Two service options available:
  - Option 1: Ready-to-bury underground option, coated with either powder coated phenolic epoxy finish or liquid applied epoxy primer coat followed by urethane top coat, supplied with composite AG/UG dome.
  - Option 2: Aboveground option, coated with either powder coated TGIC polyester finish or liquid applied epoxy primer coat followed by urethane top coat, supplied with steel AG/UG dome.
- All vessels are shipped vacuum pre-purged to enable simplified first fill of the vessel.